

MAX6652 System Monitor Combines Voltage Monitoring with Temperature Sensing

The MAX6652 temperature sensor combines voltage and overtemperature monitoring into a single integrated circuit. This device features an 8-bit analog-to-digital converter (ADC) for monitoring four window voltages with programmable threshold levels and a temperature sensor for monitoring overtemperature conditions. An ALERT-bar output can be used to interrupt a microcontroller if a fault condition is detected. The device communicates through a 2-wire interface.

This application note shows four examples of how to implement the MAX6652 into a design.

The MAX6652 is a system-monitor chip with a 2-wire digital interface. It automatically monitors system temperature and four voltages, measuring each with an 8-bit analog-to-digital converter (ADC) once every 300ms (max). Temperature and voltage measurements are continuously compared against programmable thresholds: upper and lower thresholds for voltage and a single over-temperature threshold for temperature. When temperature is too high or when a voltage falls outside of the allowed window, an interrupt is generated that notifies the system controller that a problem exists.

The sensitivities of the voltage monitor inputs have been scaled so that inputs of 12V, 5V, 3.3V, and 2.5V will yield ADC output codes of 192 (or 3/4 of full scale). When the voltages being monitored are the same as these nominal values, it is easy to set up alarm thresholds for, say, 5% above and 5% below the nominal voltage levels.

The MAX6652 can also be used to monitor input voltages that are significantly different from the nominal values, provided that the correct detection thresholds are chosen. A few examples will illustrate how this is done.

Example 1: Nominal Case.

V_{CC} = 5V; monitored voltages are 12V, 5V, 3.3V, and 2.5V.

In this example, if each voltage is at the nominal value and the ADC has no error, the ADC will produce an output code of 192 for each input. More accurately, the nominal input voltage is the threshold at which the code changes from 191 to 192. Therefore, when we calculate an ideal code, we always round down to the nearest integer value. For alarms 5% above and below the nominal input voltages, we have (rounded down to the nearest integer values):

$$\text{high limit} = 192 \times 1.05 = 201$$

and

$$\text{low limit} = 192 \times 0.95 = 182$$

The total unadjusted error of the ADC is 1% of full scale (maximum) or 2.56LSBs, so consider this potential error when choosing voltage limits.

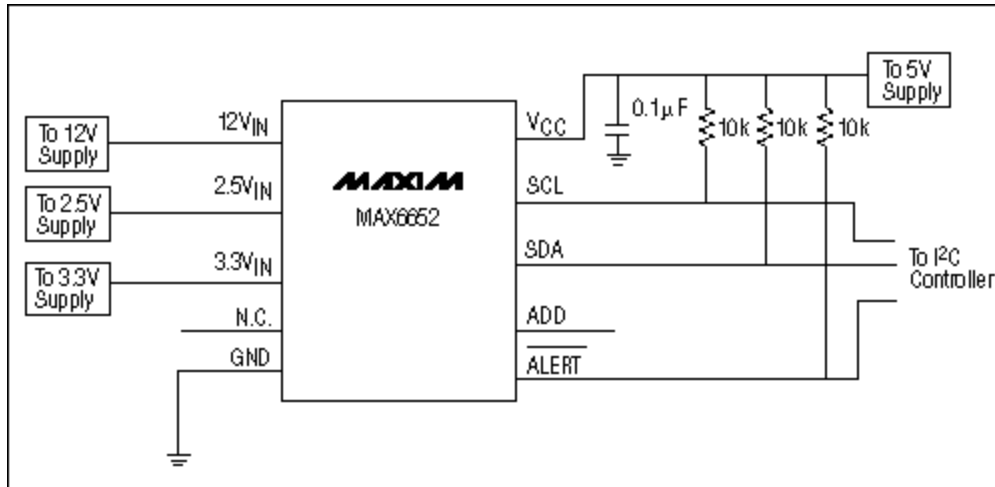

Figure 1. Circuit of Example 1. All input voltages are at the nominal values.

Table 1. Output Codes and $\pm 5\%$ Limits for the MAX6652 Used to Monitor the Nominal Power-Supply Voltages

Monitored Voltage	MAX6652 Input	Nominal Output Code	-5% Limit	+5% Limit
12	12V _{IN}	192	182	201
5	V _{CC} (5V _{IN})	192	182	201
3.3	3.3V _{IN}	192	182	201
2.5	2.5V _{IN}	192	182	201

Example 2: V_{CC} = 3.3V.
Monitored voltages are 12V, 5V, 3.3V, and 2.5V.

This example is similar to the first one, except that the MAX6652 operates from a 3.3V supply instead of the nominal 5V supply. Measuring the 3.3V supply is simple. First calculate the code that corresponds to 3.3V at the V_{CC} pin (rounded down to the nearest integer value):

$$192 \times 3.3\text{V}/5\text{V} = 126$$

Then calculate the codes for the high and low limits, again rounded down to the nearest integer values. For alarms 5% above and below the 3.3V nominal power-supply voltage, we have the following:

$$\text{high limit} = 192 \times 3.3\text{V}/5\text{V} \times 1.05 = 133$$

and

$$\text{low limit} = 192 \times 3.3\text{V}/5\text{V} \times 0.95 = 120$$

Monitoring 5V is more difficult in this example. The 5V can't be applied directly to the 3.3V_{IN} input, because that input is scaled for a maximum input voltage of 4.383V. A resistive voltage divider, as shown in Figure 2, attenuates the 5V supply so that it can be measured at the 3.3V_{IN} input. Using a 39kΩ and a 20kΩ resistor, 5V applied to the divider results in a voltage at the 3.3V_{IN} pin of:

$$V_{\text{IN}} = 5\text{V} \times 39\text{k}\Omega/59\text{k}\Omega = 3.305\text{V}$$

This produces a code equal to 192, so the ±5% thresholds are at 182 and 201.

The limits for the 12V and 2.5V inputs are the same as in the first example.

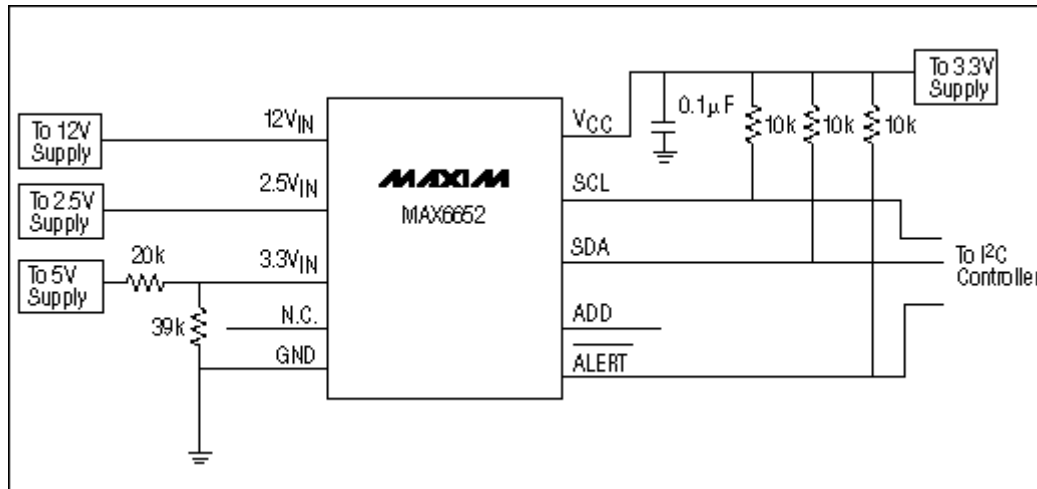

Figure 2. Circuit of Example 2. The same as Example 1, but the MAX6652 operates from a 3.3V supply, which necessitates attenuating the 5V supply so that it can be monitored at the 3.3V_{IN} input.

Table 2. Output Codes and $\pm 5\%$ Limits for the MAX6652, Monitoring the Nominal Power-Supply Voltages but with a 3.3V Supply Voltage for the MAX6652

Monitored Voltage	MAX6652 Input	Nominal Output Code	-5% Limit	+5% Limit
12	$12V_{IN}$	192	182	201
5	$3.3V_{IN}$ (attenuated)	192	182	201
3.3	V_{CC} ($5V_{IN}$)	126	120	133
2.5	$2.5V_{IN}$	192	182	201

Example 3: Low-voltage system.

$V_{CC} = 3.3V$; monitored voltages are 5V, 3.3V, 2.5V, and 1.8V.

The 3.3V supply voltage can be monitored as in Example 2.

The $12V_{IN}$ pin is available for monitoring the 5V supply. With 5V applied to this input, the output code will be as follows:

$$192 \times 5/12 = 80$$

For alarms 5% above and below the 5V nominal power-supply voltage, we have the following:

$$\text{high limit} = 192 \times 5V/12V \times 1.05 = 84$$

and

$$\text{low limit} = 192 \times 5V/12V \times 0.95 = 76$$

The $3.3V_{IN}$ pin will be used for monitoring the 1.8V supply voltage. With 1.8V applied to this input, the output code (rounded down) will be as follows:

$$192 \times 1.8/3.3 = 104$$

For alarms 5% above and below the 1.8V nominal power-supply voltage, we have (rounded down):

$$\text{high limit} = 192 \times 1.8V/3.3V \times 1.05 = 109$$

and

$$\text{low limit} = 192 \times 1.8V/3.3V \times 0.95 = 99$$

The 2.5V input limits are the same as in the first two examples.

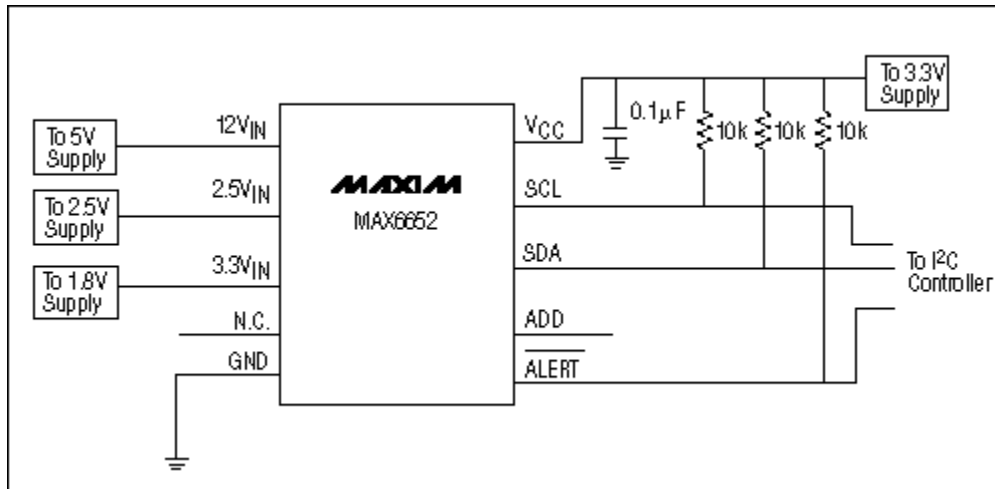

Figure 3. Circuit of Example 3. This circuit is used in a low-voltage system to monitor 5V, 3.3V, 2.5V, and 1.8V. The MAX6652 operates from a 3.3V supply. The 12V_{IN} input monitors the 5V supply, and the 3.3V_{IN} input monitors the 1.8V supply.

Table 3. Output Codes and ±5% Limits for the MAX6652 in a Low-Voltage System, Monitoring 5V, 3.3V, 2.5V, and 1.8V

Monitored Voltage	MAX6652 Input	Nominal Output Code	-5% Limit	+5% Limit
5	12V _{IN}	80	76	84
3.3	V _{CC} (5V _{IN})	126	120	133
2.5	2.5V _{IN}	192	182	201
1.8	3.3V _{IN}	104	99	109

Example 4: Alternative low-voltage system.

V_{CC} = 3.3V; monitored voltages are 5V, 3.3V, 2.5V, and 1.8V.

This is an alternative to Example 3. In this example, the 1.8V supply is monitored at the 2.5V_{IN} input instead of at the 3.3V_{IN} input, and the 2.5V supply is monitored at the 3.3V_{IN} input. This improves the measurement resolution for the 1.8V supply, while making the resolution for the 2.5V supply somewhat worse relative to Example 3.

The 3.3V supply voltage is monitored as in Examples 2 and 3.

The 12V_{IN} pin monitors the 5V supply as in Example 3.

The 3.3V_{IN} pin will be used for monitoring the 2.5V supply voltage. With 2.5V applied to this input, the output code (rounded down) will be as follows:

$$192 \times 2.5/3.3 = 145$$

For alarms 5% above and below the 2.5V nominal power-supply voltage, we have (rounded down):

$$\text{high limit} = 192 \times 2.5\text{V}/3.3\text{V} \times 1.05 = 152$$

and

$$\text{low limit} = 192 \times 2.5\text{V}/3.3\text{V} \times 0.95 = 138$$

The 2.5V_{IN} pin will be used for monitoring the 1.8V supply voltage. With 1.8V applied to this input, the output code (rounded down) will be as follows:

$$192 \times 1.8/2.5 = 138$$

For alarms 5% above and below the 2.5V nominal power-supply voltage, we have (rounded down):

$$\text{high limit} = 192 \times 1.8/2.5 \times 1.05 = 145$$

and

$$\text{low limit} = 192 \times 1.8/2.5 \times 0.95 = 131$$

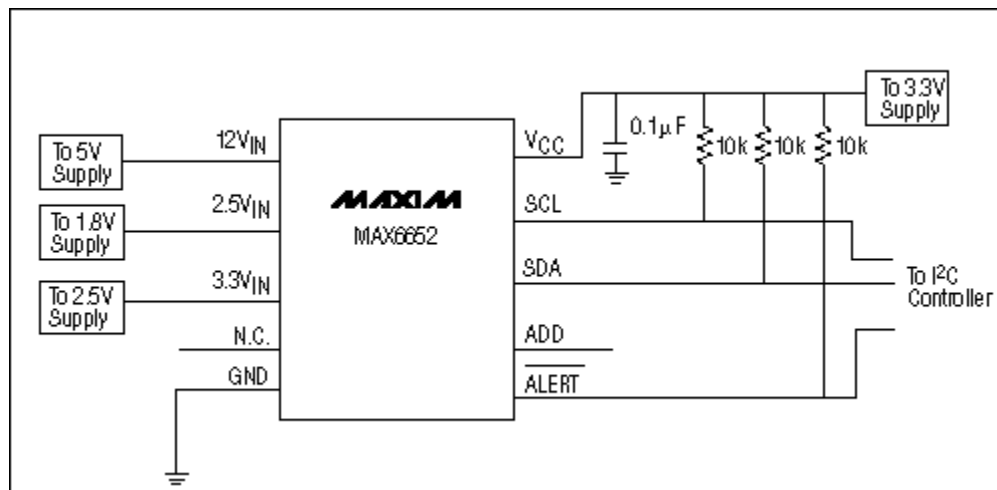

Figure 4. Circuit of Example 4. This circuit is an alternative to the low-voltage circuit in Example 3. Monitored voltages are still 5V, 3.3V, 2.5V, and 1.8V, but the inputs to the 3.3V_{IN} and 2.5V_{IN} pins are swapped to give better resolution when measuring the 1.8V supply.

Table 4. Output Codes and $\pm 5\%$ Limits for the MAX6652 in the Alternative Low-Voltage System, Monitoring 5V, 3.3V, 2.5V, and 1.8V

Note that the 1.8V input voltage produces a larger ADC code, resulting in a higher-resolution measurement.

Monitored Voltage	MAX6652 Input	Nominal Output Code	-5% Limit	+5% Limit
5	$12V_{IN}$	80	76	84
3.3	$V_{CC} (5V_{IN})$	126	120	133
2.5	$3.3V_{IN}$	145	138	152
1.8	$2.5V_{IN}$	138	131	145

MORE INFORMATION

MAX6652: [QuickView](#) -- [Full \(PDF\) Data Sheet \(176k\)](#) -- [Free Sample](#)